

DATE	ISSUE
05/08/01	DRW.
05/10/01	ISSUED FOR CONSTRUCTION
06/06/01	SAN & WATER

INDEX

SITE PLAN	SD-1
FLOOR PLAN	A-1
ELEVATIONS	A-2
TYPICAL SECTION	A-3
FOUNDATION PLAN	S-1
STRUCTURAL DETAILS	S-2
STRUCTURAL DETAILS	S-3

GENERAL NOTES

- All construction and materials shall be in accordance with the Standards of the City of Bowling Green and the specifications of the State of Ohio Department of Transportation dated January 1, 1997, subject to any addenda by the City of Bowling Green.
- The contractor for this project shall contact the City of Bowling Green for any inspection required during construction.
- The location of all utilities is approximate. The exact location of all utilities shall be the contractor's responsibility. The contractor shall contact the Ohio Utilities Protection Service (OUPS, 1-800-362-2764) at least two (2) working days prior to commencing work. Non-members must be called directly.
- The contractor shall be responsible for any and all damage to existing utilities caused by his operations.
- Roof drains, foundation drains, and other clean water connections to the sanitary sewer are prohibited.
- Remove topsoil (9"±) at proposed building location and in paving areas. Stockpile enough topsoil for backfilling around proposed building. Excess excavation shall be hauled offsite.
- Add 600 to proposed elevations to obtain true elevation.

SITE DATA

ACREAGE: 10.872 Ac.±
 LOTS: (TOTAL LOTS: 3)
 MINIMUM LOT SIZE: 103,000 S.F.
 AVERAGE LOT SIZE: 250' x 450'
 MINIMUM FRONTAGE: 107' AT BLDG. LINE
 FRONT YARD = 35'
 SIDE YARD = 50'
 REAR YARD = 40'

ZONING
 EXISTING: M-2

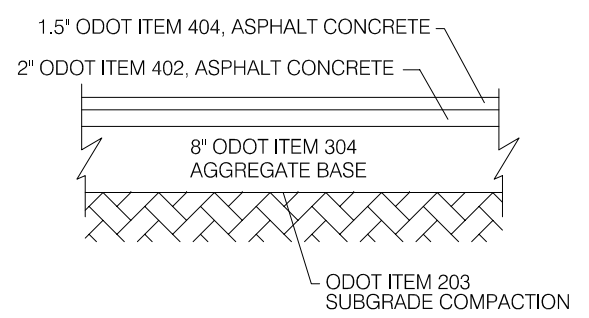

TYPICAL PAVEMENT SECTION

NEW COMMERCIAL BUILDING
 LOT 16-C
 WOOD-BRIDGE COMMONS
 BOWLING GREEN, OH

COLONY + COLONY LTD.
 CIVIL ENGINEERS
 2726 Monroe St. Toledo, Oh 43606
 419-243-4476 419-243-4686 fax

DRAWING TITLE:	SITE PLAN
JOB NO.	0051
DATE:	MARCH 2001
SHT. NO.	SD1